



Sustainable Nitrogen Management Seminar 2025
– Accumulation of nitrogen data in EANET –
2025/12/22

Regional assessment of atmospheric nitrogen deposition
using EANET monitoring data

Kazuhide Matsuda

Professor

Tokyo University of Agriculture and Technology (TUAT)

Trend of emissions in Asia

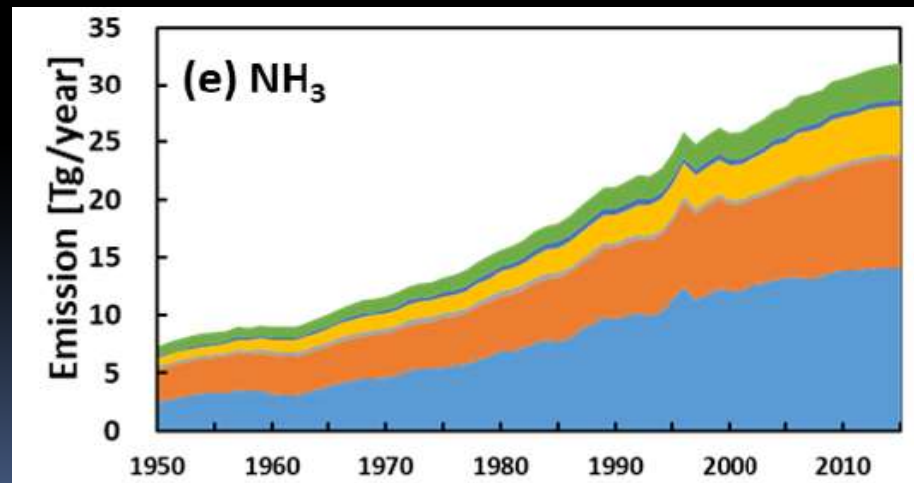
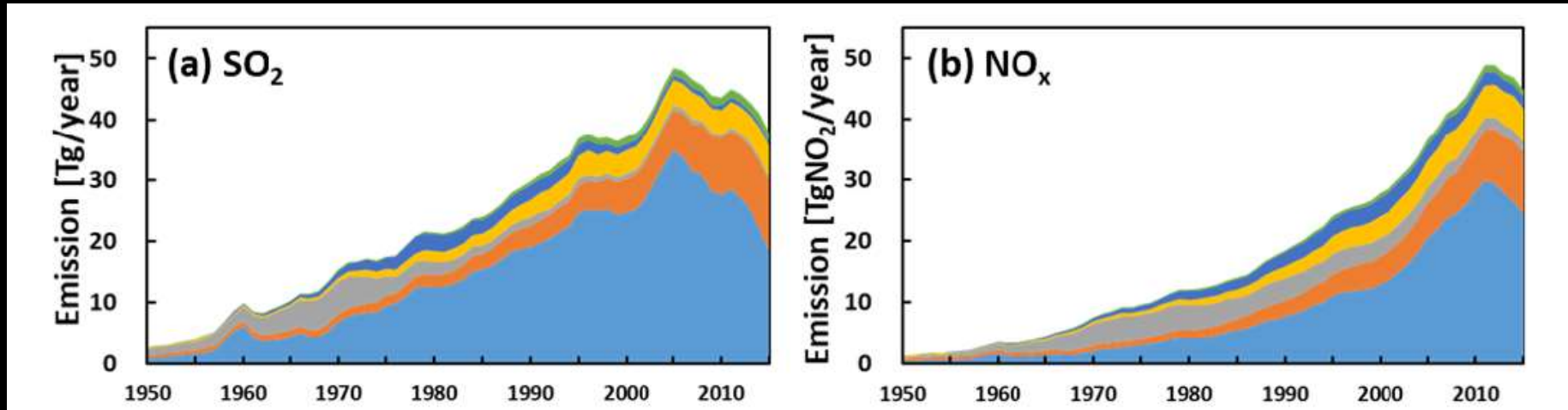

Asia Region

China India Japan SEA OEA OSA

Kurokawa and Ohara (2020)

NH₃ trends by satellite data analysis: 2013 to 2024 (Trend of the time series decomposition analysis)

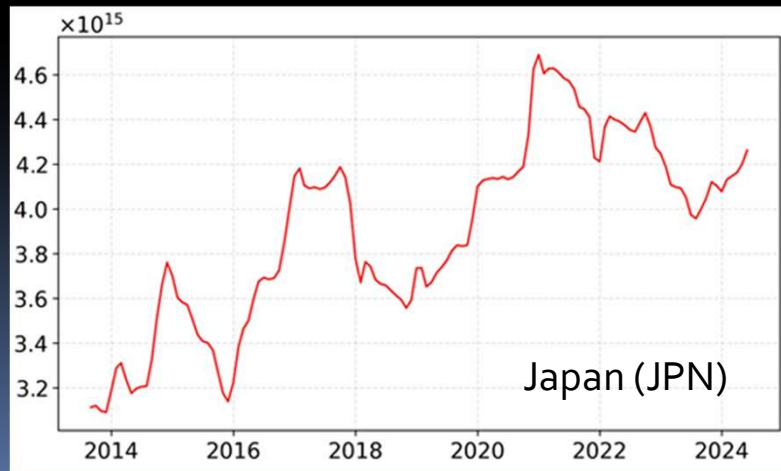
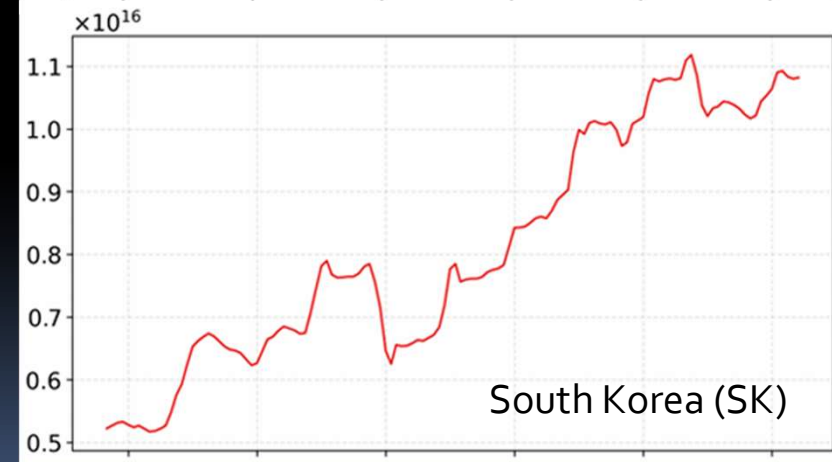
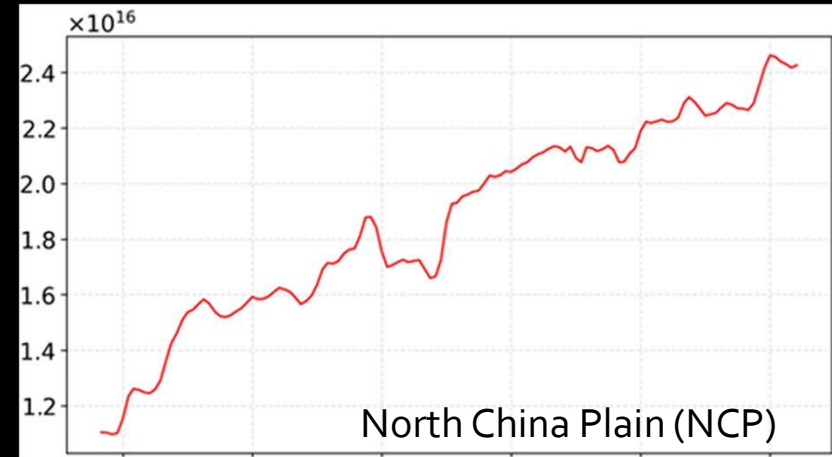
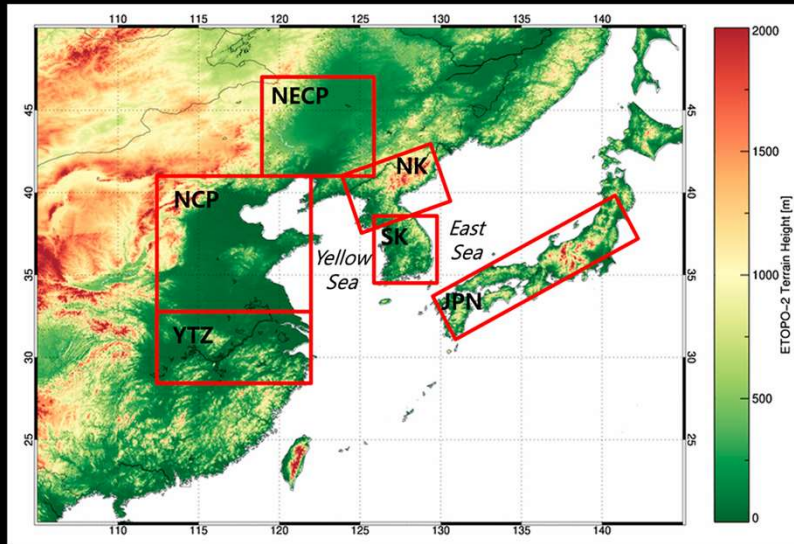

Unit: molecules cm⁻²

Choi et al. (2025)

Trend of deposition ratio of N / S in Japanese remote EANET sites

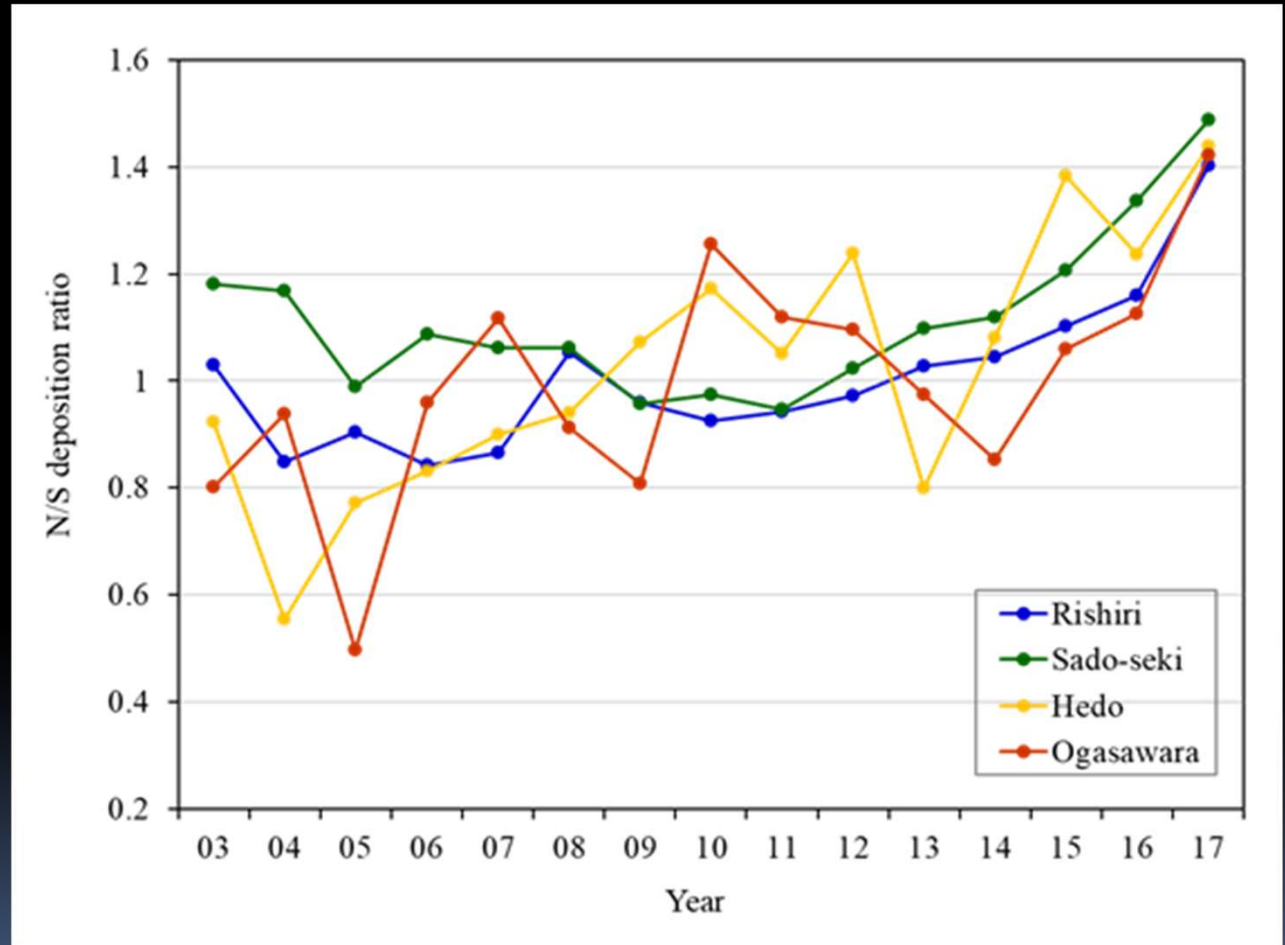
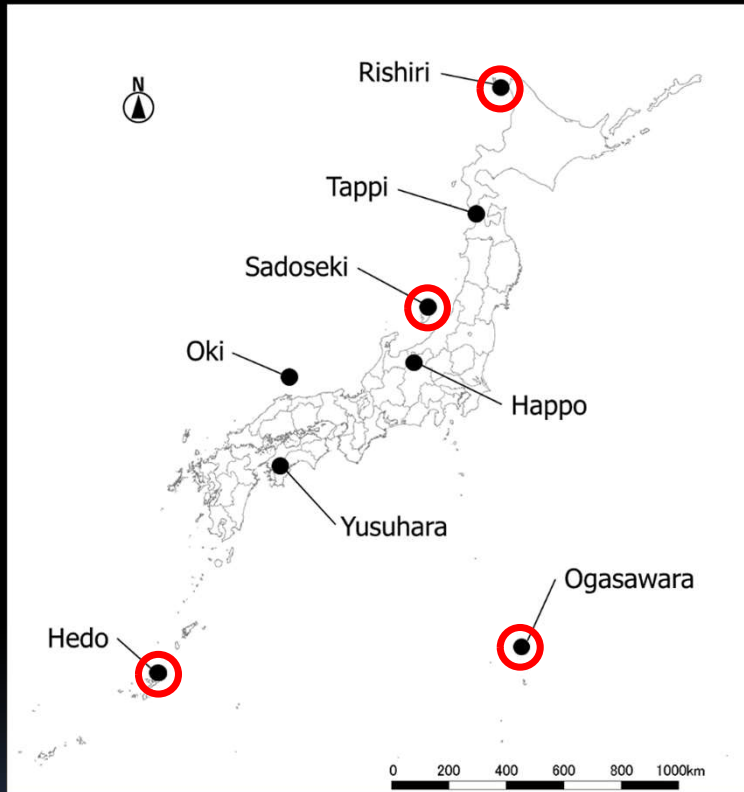

Matsuda (2024)

Relationship between sources and receptors of air pollution

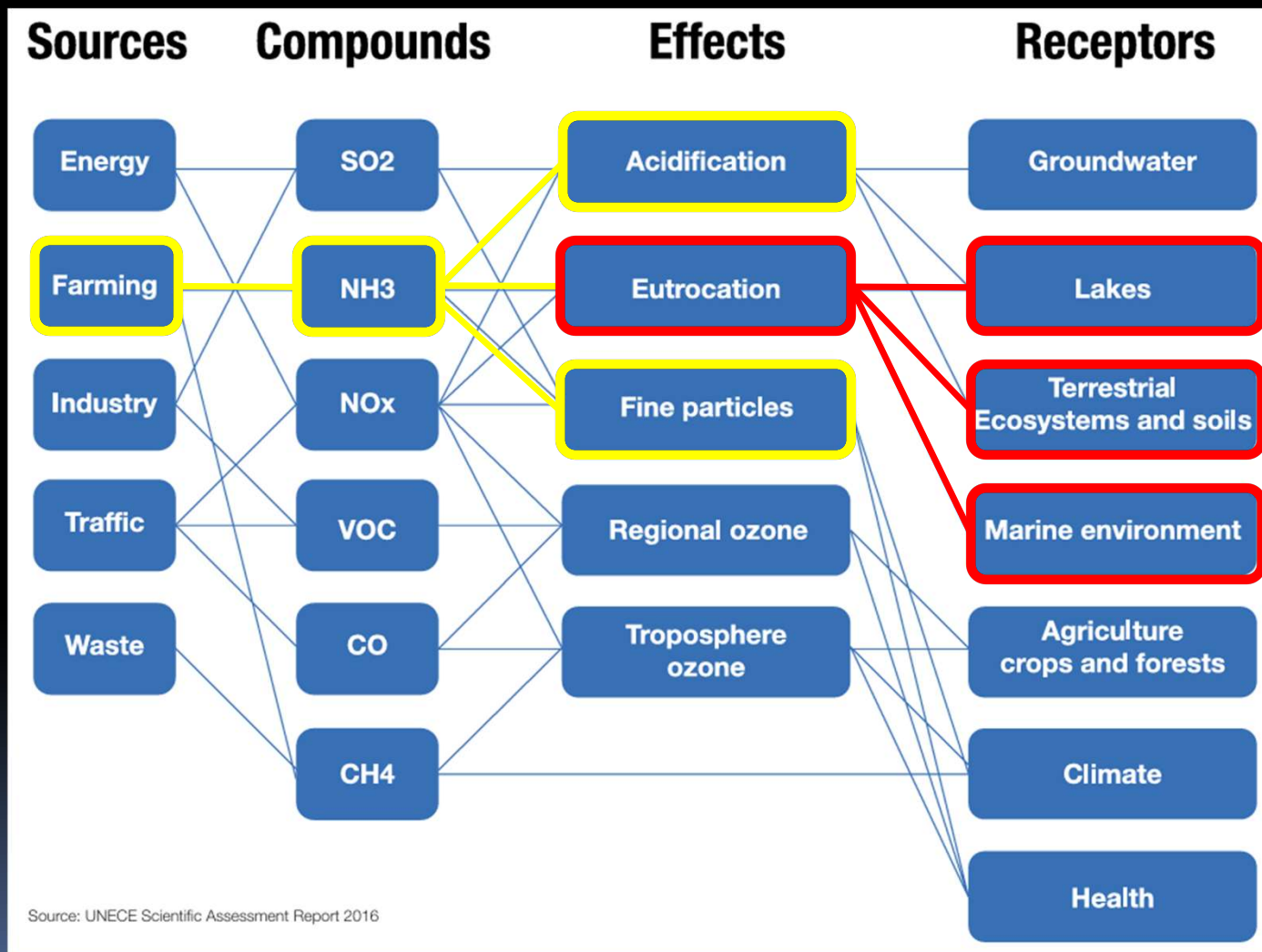



Distr.: General
28 March 2019

Original: English



**United Nations
Environment Assembly of the
United Nations Environment
Programme**

**United Nations Environment Assembly of the
United Nations Environment Programme
Fourth session
Nairobi, 11–15 March 2019**

**Resolution adopted by the United Nations Environment
Assembly on 15 March 2019**

4/14. Sustainable nitrogen management

The United Nations Environment Assembly,

Recognizing the multiple pollution threats resulting from anthropogenic reactive nitrogen, with adverse effects on the terrestrial, freshwater and marine environments, and to air pollution and greenhouse gas emissions, while acknowledging the benefits of nitrogen use for food and energy production,

Recognizing also that global crop production and food security are dependent on nutrients, including nitrogen and phosphorus resource use

Outline of Japan's National Action Plan on Sustainable Nitrogen Management

September 2024

- In accordance with the **UNEA resolutions on sustainable nitrogen management**, Japan's national action plan on sustainable nitrogen management was formulated based on the **6th Basic Environmental Plan**.
- As an **integrated approach to conservation and management of the water and atmospheric environment with decarbonization, resource circulation and symbiosis with nature**, collaborative projects among relevant ministries will be developed to **benefit societies and regions** through nitrogen management.
- Japan will contribute to **Asian countries' nitrogen management** by **promoting knowledge and experience sharing, capacity building and technology transfer**.

1. Achievements of nitrogen management and remaining issues

- Set emission standards for NOx discharged from factories and allowable limits for NOx from mobile sources such as automobile exhaust gas regulating the total amount of NOx emission with the Air Pollution Control Act.
- Established effluent standards for factories or workplaces discharging effluent with the Water Pollution Prevention Act.
→As a result of the efforts, **air and water pollution caused by reactive nitrogen in Japan has been improved dramatically.**
- Not achieving the environmental standards for **nitrate nitrogen and nitrite nitrogen in the groundwater and total nitrogen in lakes** in some areas continuously.
- **In some enclosed seas, there are deficiencies in nutrients affecting marine resources.**
- Balancing the **expected increasing use of ammonia fuel for carbon neutrality and the reduction in nitrogen emissions** to the atmospheric environment is crucial.
- Expecting consolidation of scientific knowledge, **elaboration on the nitrogen inventory** and further technology developments for establishing nitrogen supply chain.

2. Integrated approaches of environmental management with CN, CE, NP

Establishing the **comprehensive material flow** of nitrogen, which is across various media such as water and air and considering effective actions.

(1) Carbon Neutral

- **Providing nutrients from wastewater treatment facilities** to realize the "Clean and Rich Sea" while examining **energy efficiency**.
- **Improving water quality** in rivers, lakes and groundwater sourcing drinking water and utilizing **livestock manure for energy**.
- Utilizing **technologies for NOx emission control** to address the **increasing use of ammonia**.

(2) Circular Economy

- **Facilitating best practices of fertilizer and livestock manure management, the use of manure and sewage sludge resources.**
- Effective use of **bottom sediment resources of eutrophicated lakes**.
- Promoting ethical consumption and reducing food loss.
- Considering **nitrogen supply chain**.
e.g.) recovering ammonia from wastewater treatment facilities.

(3) Nature Positive

- **Realizing "Clean and Rich Sea"** through promoting active operations management for nutrients in wastewater treatment facilities, and **conservation and restoration of seaweed beds and tidal flats**.

3. International Cooperation on Sustainable Nitrogen Management

- Sharing Japan's knowledge and experience and facilitating capacity building for administrative officials with **EANET (Acid Deposition Monitoring Network in East Asia)** and **WEPA (Water Environment Partnership in Asia)**.
- Promoting introduction of Japan's technologies through the **Cobenefits projects** of air quality improvement and climate change mitigation and the **Model Project for improvement of Water Environment in Asia**.

<https://www.env.go.jp/content/000264695.pdf>

“Major N-deposition Species”

| | | |
|--------------------|--------------------------------------|-----------------|
| ▪ Wet deposition : | NO_3^- , | NH_4^+ |
| ▪ Dry deposition : | gas NO_2 , HNO_3 , | NH_3 |
| | aerosol NO_3^- , | NH_4^+ |
| | Oxidized N | Reduced N |

“Impacts of N deposition”

- Increase of CO_2 absorption by plants
- Increase of biomass

..... **Critical level**

- **Acidification and Eutrophication**
- **Biodiversity loss**

Wright et al. (2018)₉

Wet and Dry deposition monitoring at EANET

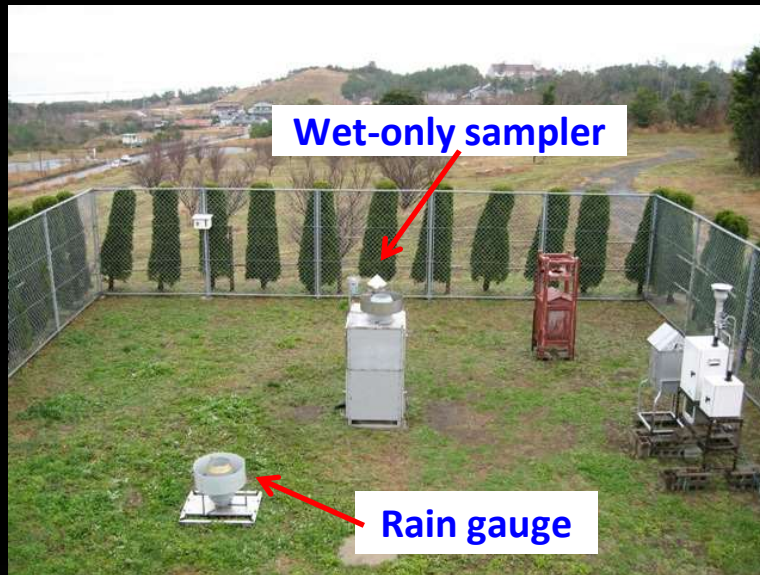

Wet deposition

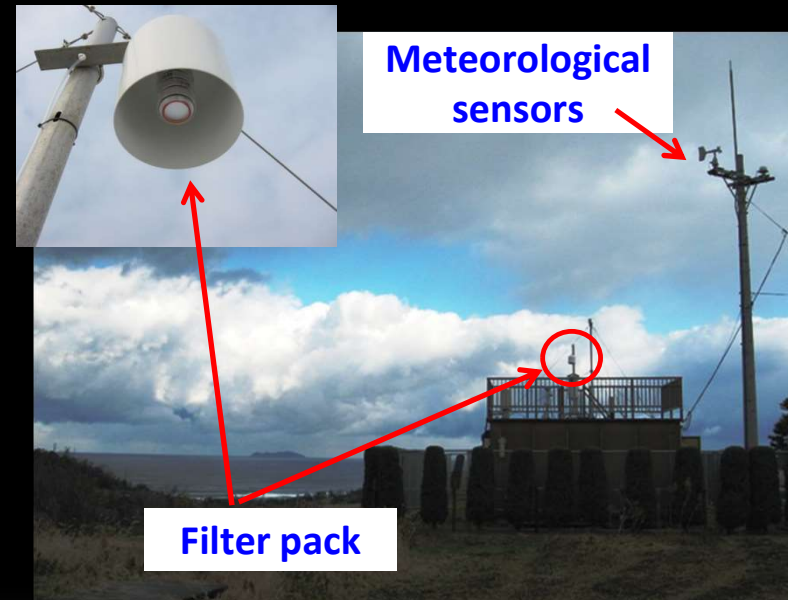

Dry deposition

Wet deposition = Concentration \times Precipitation amount

Dry deposition = Concentration \times Deposition velocity (V_d)

Calculated by
Resistance model

A method estimating dry deposition for assessment of nitrogen load on forests in East Asia

Ban, Matsuda, Ohizumi (2022)

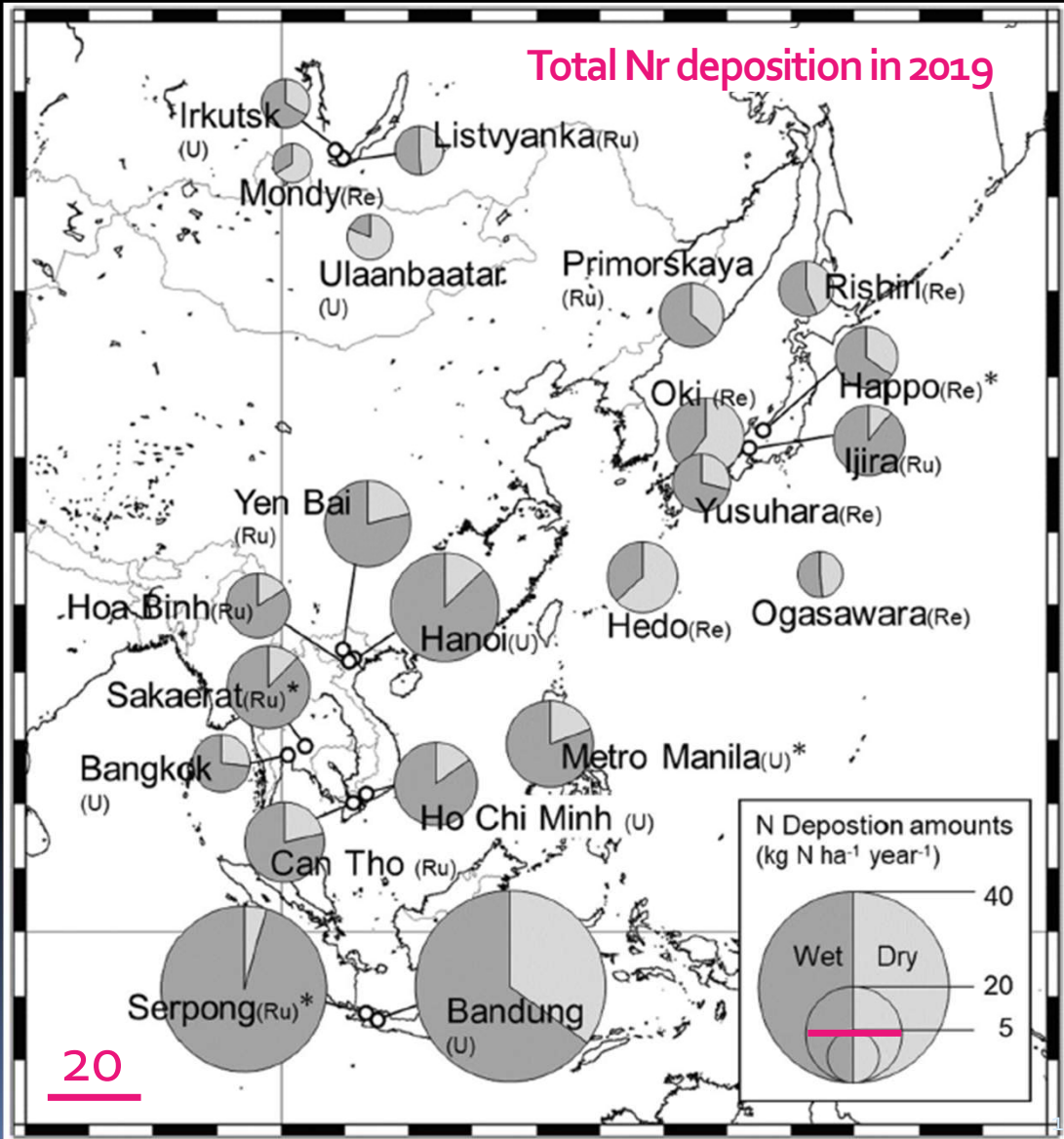

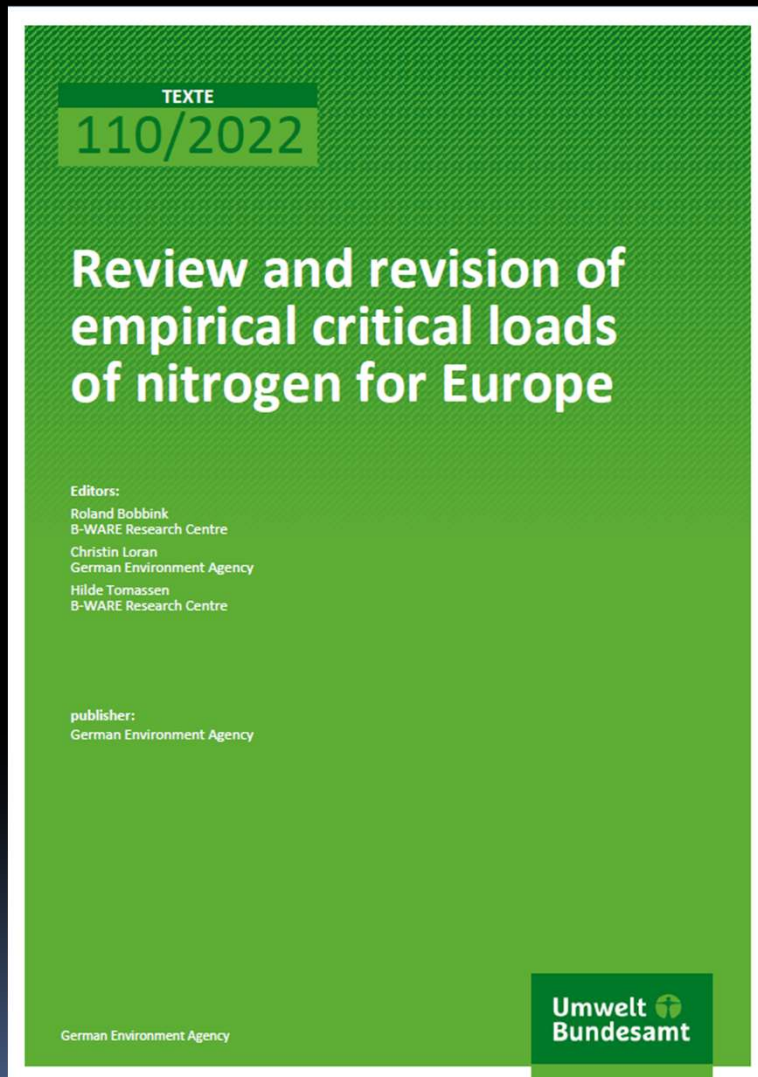

This report describes the scientific background and results from the review and revision of **empirical critical loads of nitrogen** that had been established for Europe in 2011 under the auspices of **the UNECE Convention on Long-range Transboundary Air Pollution (LRTAP Convention)**.

<https://www.apis.ac.uk/review-and-revision-empirical-critical-loads-nitrogen-europe>

Empirical N critical loads to natural and semi-natural ecosystems (examples)

| Ecosystem type | Range kg N ha⁻¹ y⁻¹ |
|---|--|
| Coastal habitats | 5 - 20 |
| Inland surface water habitats | 2 - 10 |
| Grasslands and tall forb habitats | 5 - 20 |
| Heathland, scrub and tundra habitats | 3 - 15 |
| Forest habitats | 2-15 |

Range of the values for “reliable” and “quite reliable” levels at three levels of reliability

Assessing critical loads and exceedances for acidification and eutrophication in the forests of East and Southeast Asia: **A comparison with EANET monitoring data**

Yamashita, Sase, Kurokawa (2022)

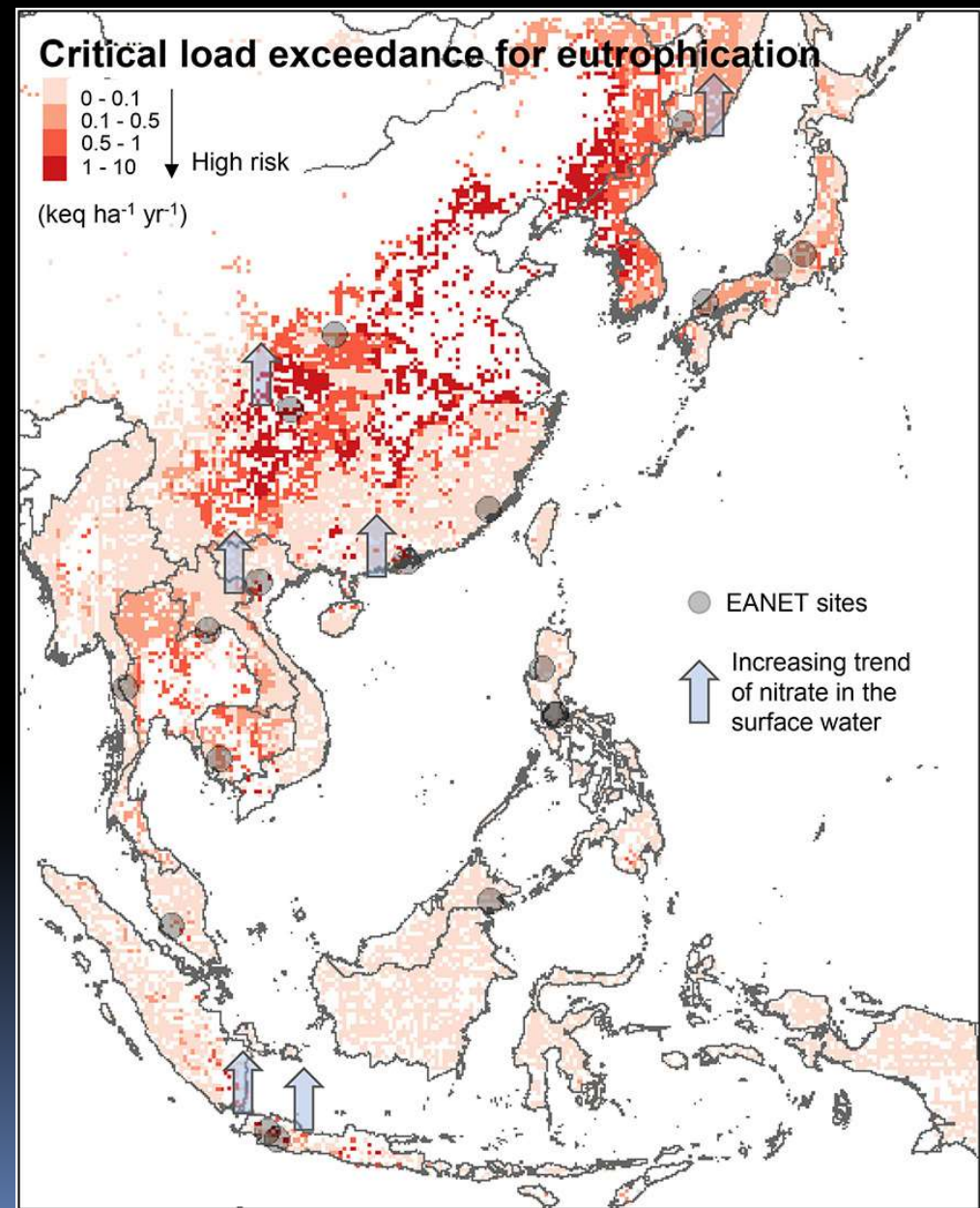

Available EANET data on reactive nitrogen (as of 2023)

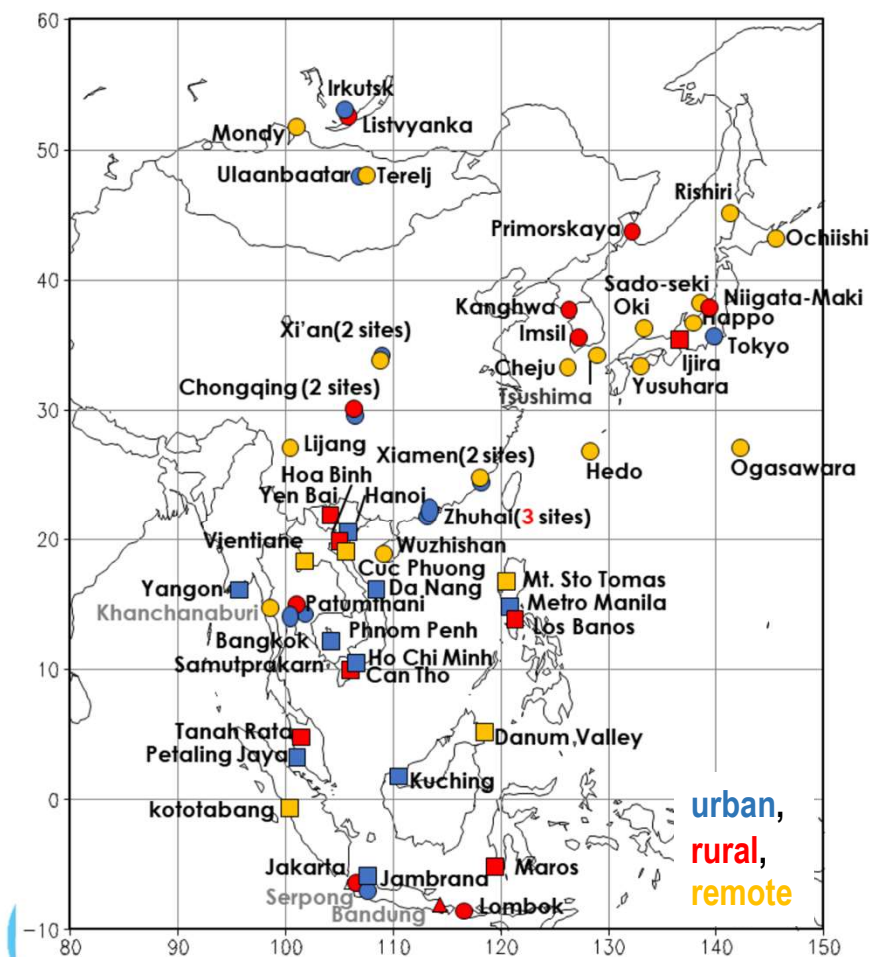

Wet deposition monitoring sites: 57 sites

| Monitoring media and monitored reactive nitrogen | Number of site | Note |
|---|-----------------------------------|--|
| Wet deposition (rainwater): NO_3^- , NH_4^+ | 57 | <u>Concentration and deposition</u> |
| Dry deposition (air concentration): Gases (HNO_3 , NH_3), Particles (NO_3^- , NH_4^+) | 36 (FP method) | <u>Concentration</u> Deposition flux (only at 11 sites in Japan) AT (NO , NO_2 , NO_x): 17 sites PS (NO_2): 2 sites |
| Inland water (lakes and rivers): NO_3^- , NH_4^+ | 17 | <u>Concentration</u> |
| Forest catchment (Atmospheric deposition and river water): NO_3^- , NH_4^+ | 2 (+1 as the project activity) | <u>Concentration, Deposition/discharge</u> (utilizing the nearest deposition data) |

FP, filter pack; AT, automatic monitor; PS, passive sampling



The Ammonia Monitoring Network (AMoN)

provides land managers, air quality modelers, ecologists, and policymakers critical data that allows them to:

- assess the long-term trends and spatial variability in ambient NH_3 concentrations and deposition;
- validate atmospheric models;
- better estimate total nitrogen inputs to ecosystems;
- assess changes in atmospheric chemistry due to SO_2 and NO_x reductions; and
- assess compliance with $\text{PM}_{2.5}$ standards.

There are currently 106 AMoN sites covering 34 states. There are 18 sites that have been operating for over 10 years.

Since 2007

Ambient Ammonia Monitoring Network (AMoN)

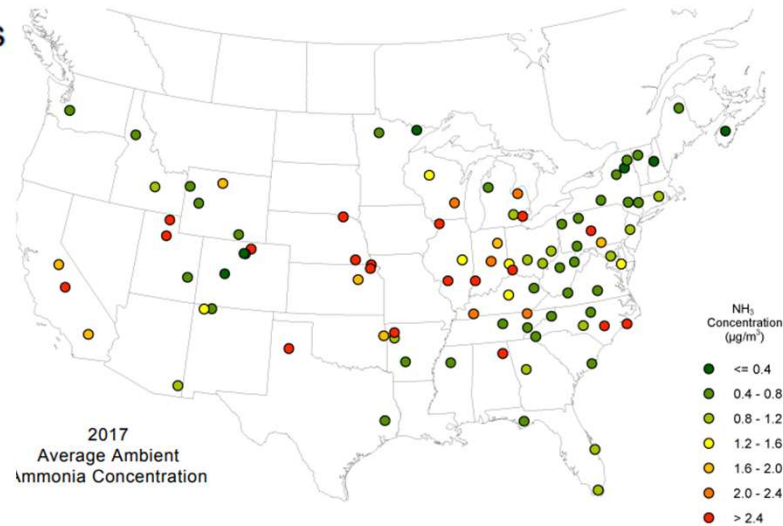

Above: Example of AMoN Sample Shelter at Beltsville, MD (MD99).
Left: Ammonia Sampler, screwed into roof of housing.

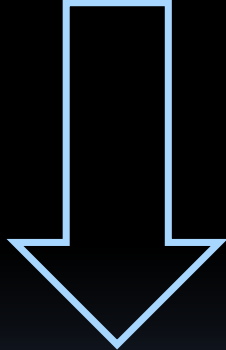
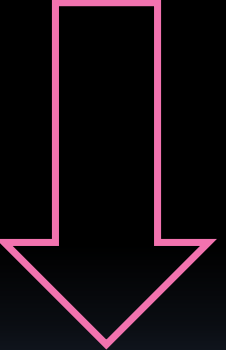
| | Procedure | Cost | Artifact |
|---------------|--|--|----------|
| ▪ Denuder | Complicated | High | No |
| ▪ Filter pack |  |  | Yes |
| ▪ Passive | Simple | Low | No |

Filter pack

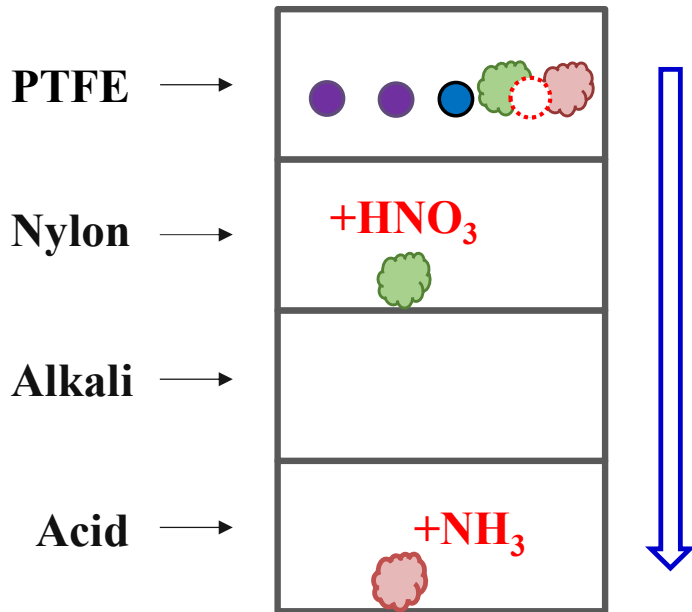
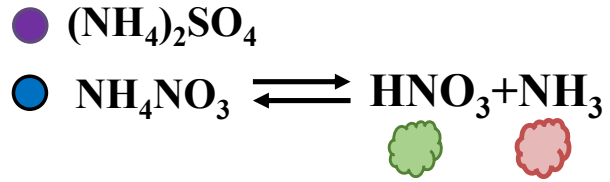

Denuder

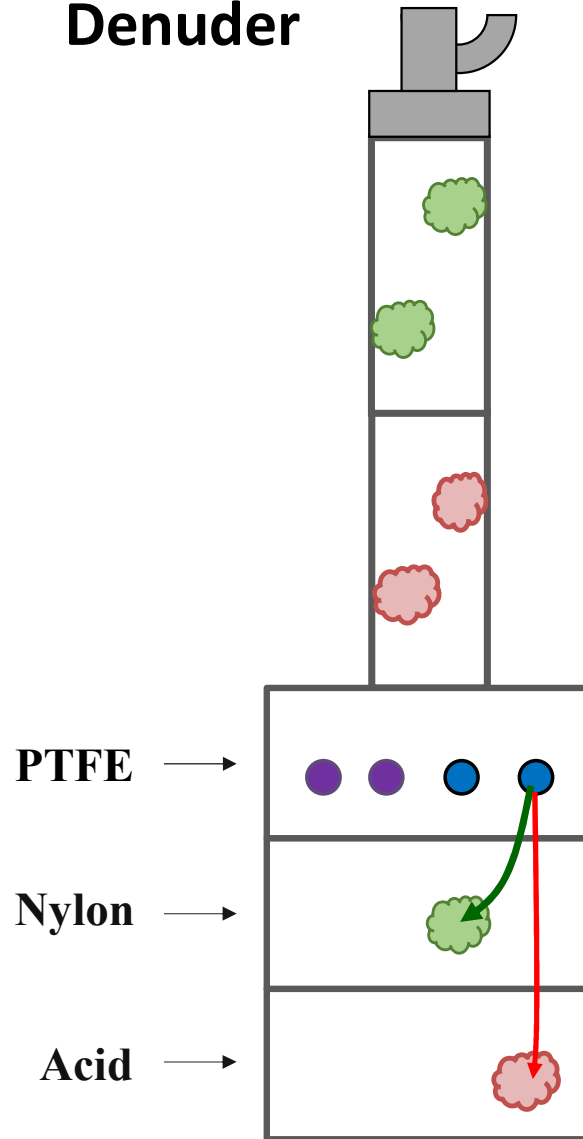

Passive sampler: OGAWA & CO., LTD.

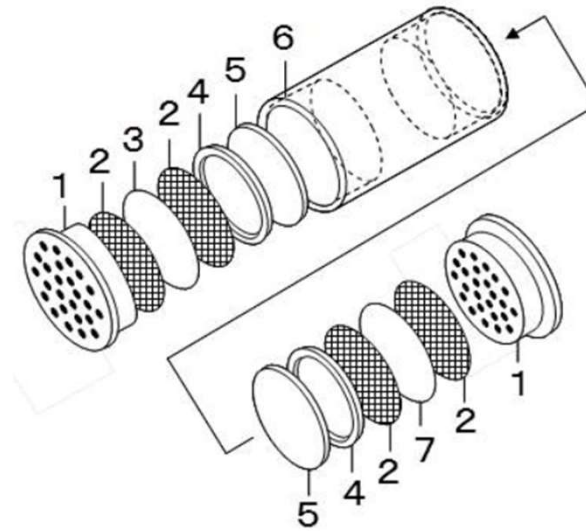

Uncertainties of NH_3 deposition estimation: Model intercomparison of the resistance models

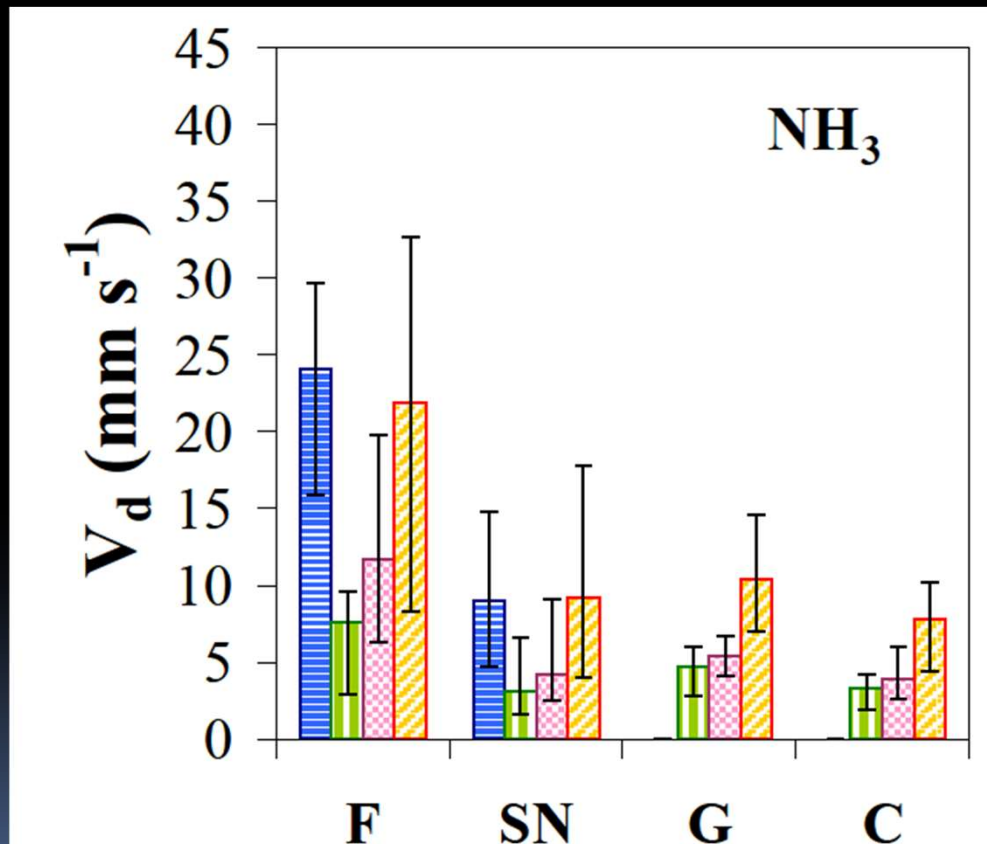

- F : Forest
- SN : Semi-natural short vegetation
- G : Grassland
- C : Cropland

Flechaerd et al. (2011)

Bi-directional exchange of NH_3 in natural ecosystems

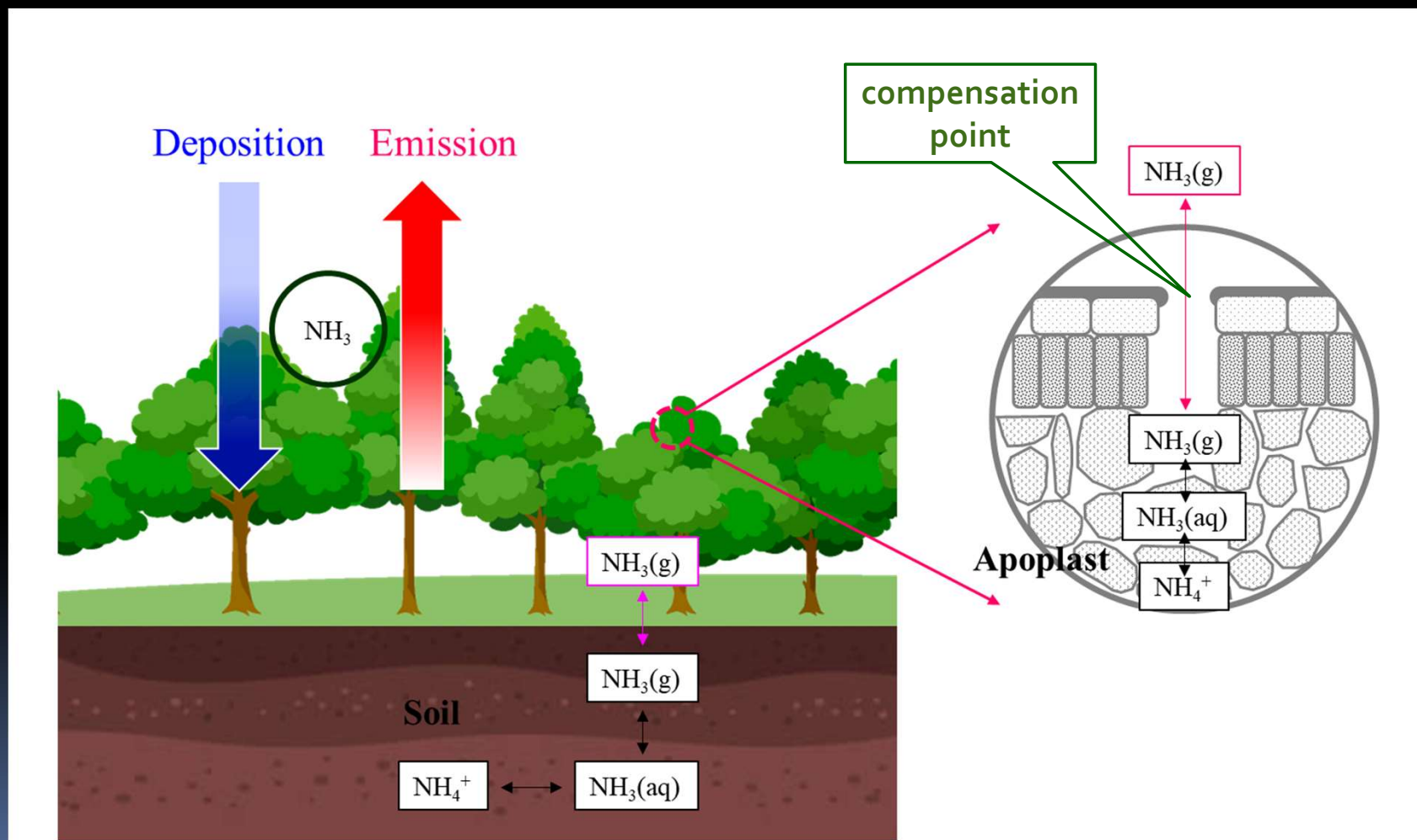

Bi-directional model for NH₃

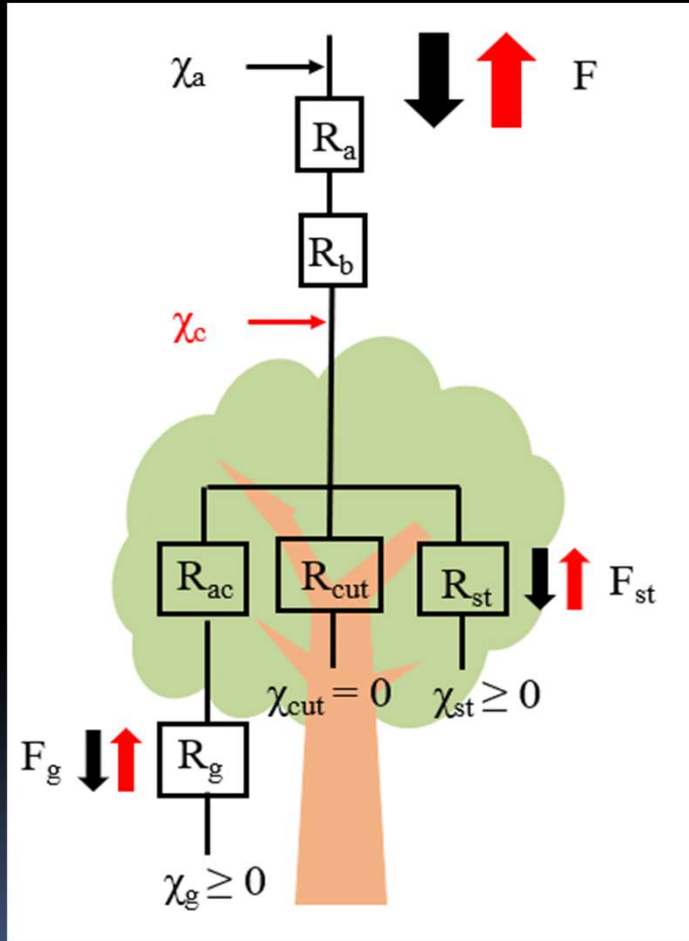

$$F = - \frac{\chi_a - \chi_c}{R_a + R_b}$$

- χ_a : NH₃ concentration
- R_a : aerodynamic resistance
- R_b : quasi-laminar layer resistance

$$\chi_c = \left(\frac{\chi_a}{R_a + R_b} + \frac{\chi_{st}}{R_{st}} + \frac{\chi_g}{R_{ac} + R_g} \right) \cdot \left(\frac{1}{R_a + R_b} + \frac{1}{R_{st}} + \frac{1}{R_{ac} + R_g} + \frac{1}{R_{cut}} \right)^{-1}$$

Zhang et al. (2010)

Exchange flux measurements by Relaxed Eddy Accumulation

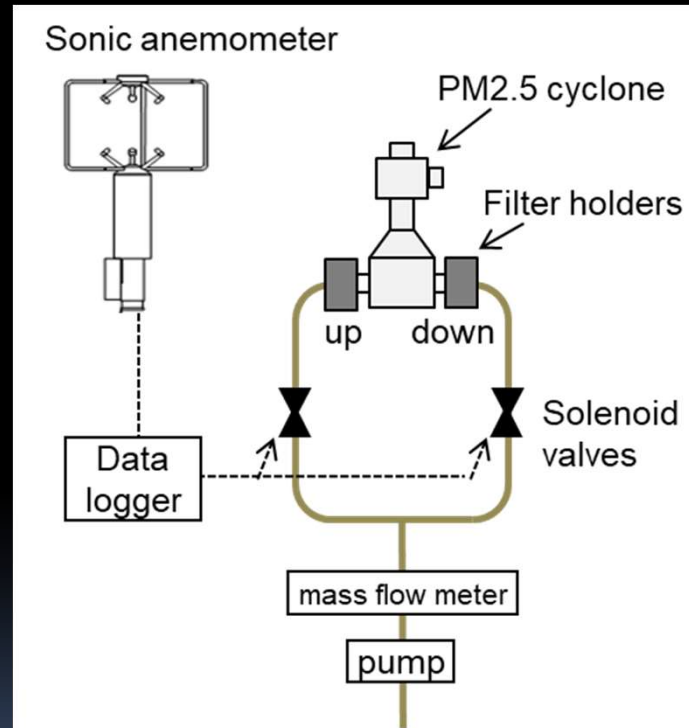

Matsuda et al. (2015)

$$\text{Flux} = \beta \sigma_w (C_{\text{up}} - C_{\text{down}})$$

β : empirical coefficient
 σ_w : standard deviation of vertical wind speed
 C_{up} : updraft concentration
 C_{down} : downdraft concentration

$$\text{Deposition velocity} = \text{Flux} / \text{Concentration}$$

Observation tower of FM Tama in deciduous broadleaf forest



western suburb in Tokyo

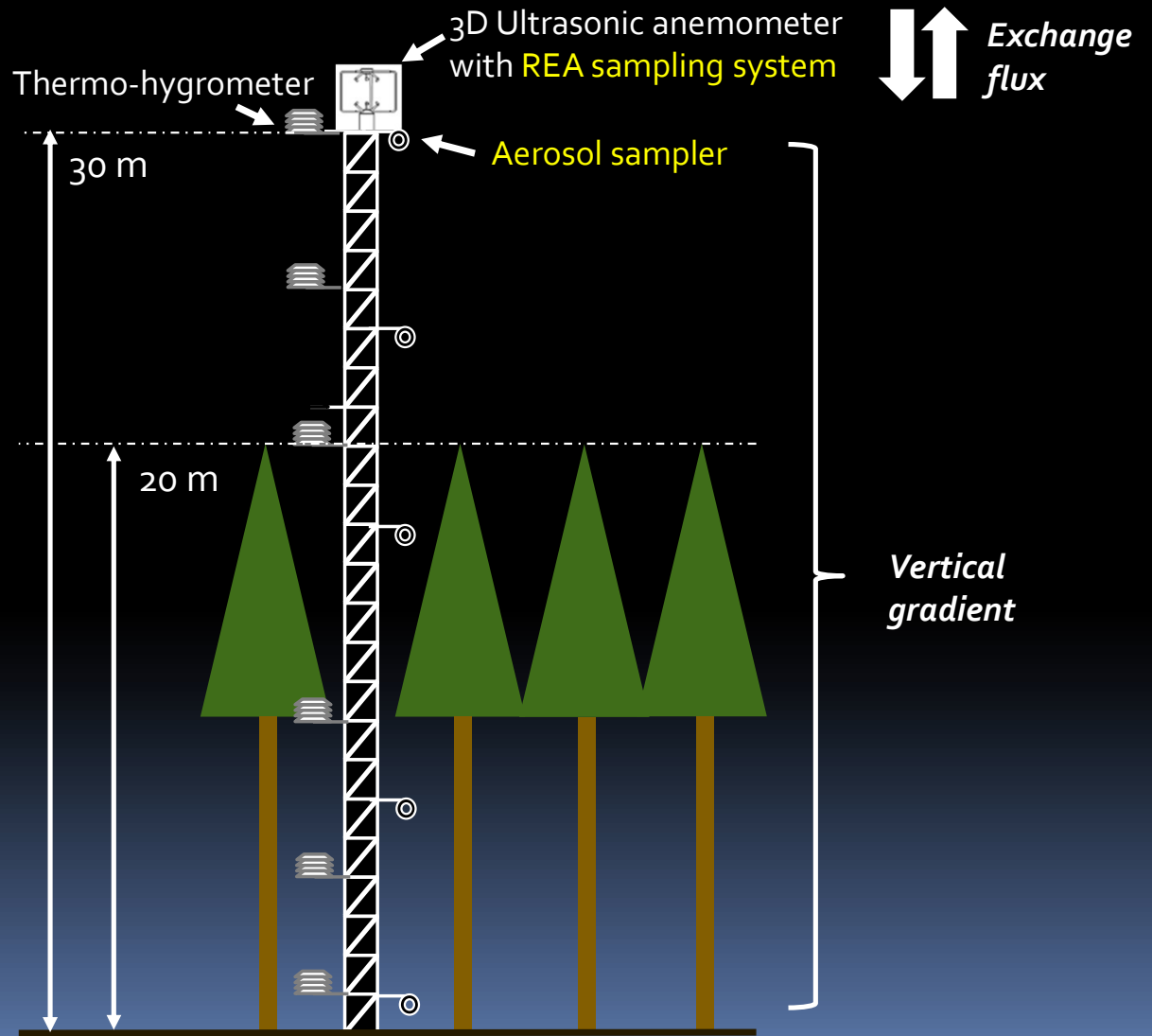



JSPS-KAKENHI project 2023-2025 Mechanism of air-tropical forest exchange of gaseous and particulate reactive nitrogen in Southeast Asia



TUAT, TISTR
Kyushu Univ.
ACAP, Toyo Univ.

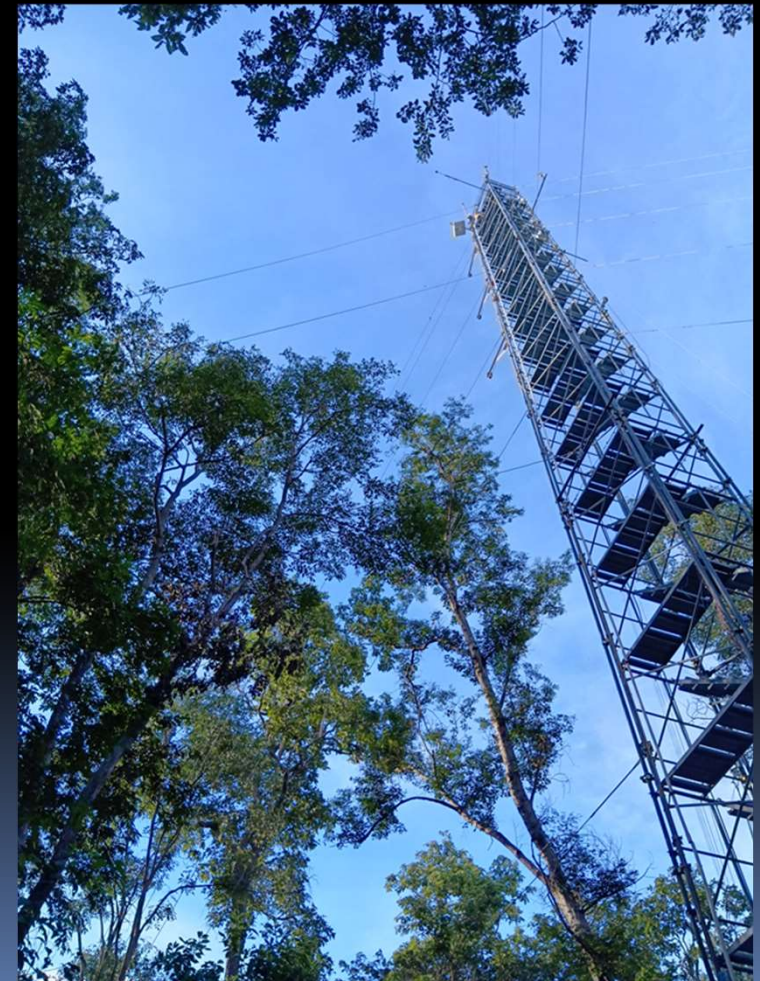

Ammonia exchange flux over a tropical dry deciduous forest in the dry season in Thailand

Atmos. Chem. Phys., 25, 18291–18312, 2025
<https://doi.org/10.5194/acp-25-18291-2025>

Mao Xu^{1,2}, Phuvasa Chanonmuang³, Hiroyuki Sase⁴, Atsuyuki Sorimachi⁵, Syuichi Itahashi², and Kazuhide Matsuda⁶

Temporal variations in NH₃ concentration at 34m (black line) and 26m (red line)

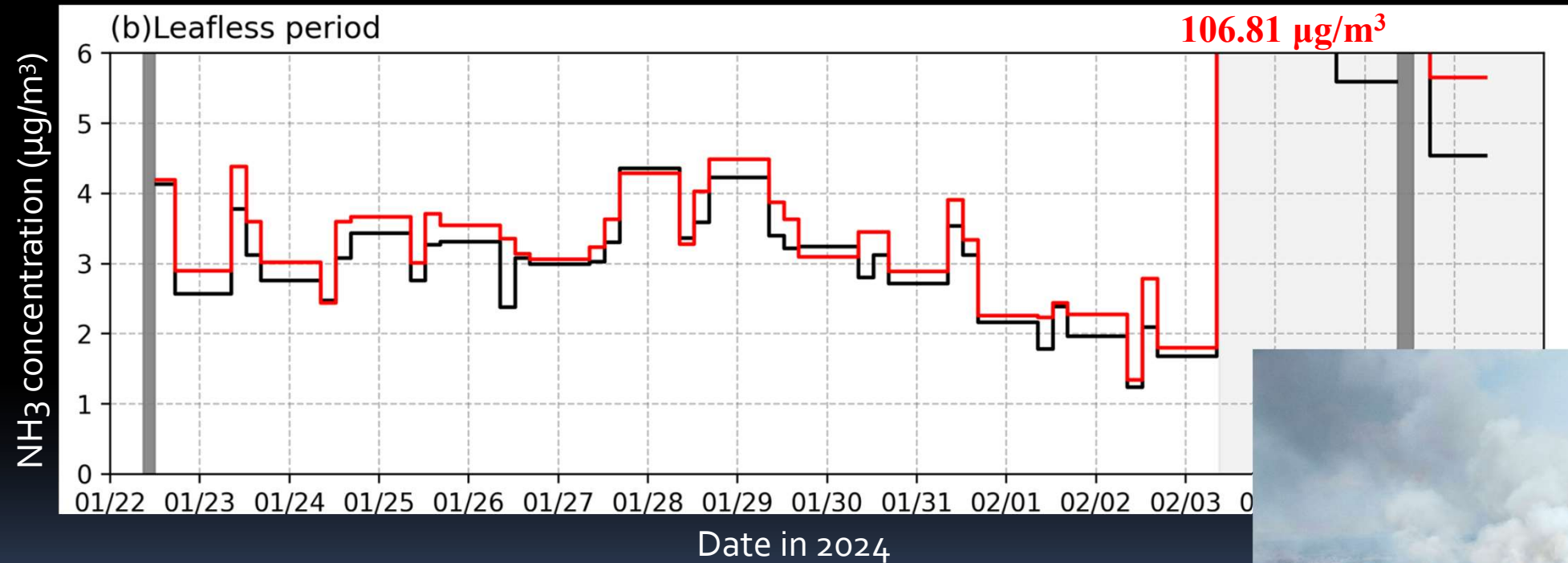

Summary

- East Asia is a region at high risk of ecological impacts due to nitrogen deposition.
- EANET monitoring covers the essential items for the assessment of nitrogen deposition amount.
- The contribution of ammonia (reduced nitrogen) to total nitrogen deposition is increasing.
- Considering the importance of ammonia monitoring, it is effective to use a passive sampler.
- There are large uncertainties to estimate ammonia dry deposition; further studies on the mechanisms are encouraged.